

Research Article

Application of Gold Nanoparticles for Electrochemical DNA Biosensor

Ahmed Mishaal Mohammed,^{1,2} Ruslinda A. Rahim,² Ibraheem Jaleel Ibraheem,¹ Foo Kai Loong,² Hasrul Hisham,² Uda Hashim,² and Yarub Al-Douri²

¹ Chemistry Department, College of Science, Al-Anbar University, Ramadi, Iraq

² Institute of Nano Electronic Engineering, Universiti Malaysia Perlis, 01000 Kangar, Perlis, Malaysia

Correspondence should be addressed to Ahmed Mishaal Mohammed; mishaal78.2010@yahoo.com

Received 20 October 2013; Accepted 3 April 2014; Published 25 May 2014

Academic Editor: M. Ghoranneviss

Copyright © 2014 Ahmed Mishaal Mohammed et al. This is an open access article distributed under the Creative Commons Attribution License, which permits unrestricted use, distribution, and reproduction in any medium, provided the original work is properly cited.

An electrochemical DNA biosensor was successfully fabricated by using (3-aminopropyl)triethoxysilane (APTES) as a linker molecule combined with the gold nanoparticles (GNPs) on thermally oxidized SiO₂ thin films. The SiO₂ thin films surface was chemically modified with a mixture of APTES and GNPs for DNA detection in different time periods of 30 min, 1 hour, 2 hours, and 4 hours, respectively. The DNA immobilization and hybridization were conducted by measuring the differences of the capacitance value within the frequency range of 1 Hz to 1 MHz. The capacitance values for DNA immobilization were 160 μF, 77.8 μF, 70 μF, and 64.6 μF, respectively, with the period of time from 30 min to 4 hours. Meanwhile the capacitance values for DNA hybridization were 44 μF, 54 μF, 55 μF, and 61.5 μF, respectively. The capacitance value of bare SiO₂ thin film was 0.42 μF, which was set as a base line for a reference in DNA detection. The differences of the capacitance value between the DNA immobilization and hybridization revealed that the modified SiO₂ thin films using APTES and GNPs were successfully developed for DNA detection.

1. Introduction

Gold nanoparticles (GNPs) with the sizes in the range of units to hundreds of nanometres lately attract a comprehensive attention in different fields of medicine, biology, physics, and chemistry as a result of their unique electronic, magnetic, optical, mechanical, physical, and chemical properties [1–3]. Gold nanoparticles have gained considerable attention in recent years for potential applications in industry and nanomedicine. Also, gold nanoparticles show promising behavior in enhancing the effectiveness of various aimed cancer treatments such as photothermal therapy and radiotherapy [4].

Applications of gold nanoparticles show strong optical dying out at near infrared and visible wavelengths which can be tuned by modifying the size. Recently advances in their high-yield synthesis, functionalization, stabilization and bioconjugation, gold nanoparticles are an increasingly applied nanomaterial. Bulk gold is perfect for being inert; however, the nanoparticulate sizes of gold show astronomically high chemical reactivity [5, 6].

The development of DNA sensors has recently attracted substantial attention in connection with research efforts directed at gene analysis, the detection of genetic disorders, tissue matching, and forensic applications [7].

DNA hybridization detection is a main issue in molecular biagnostics [8], determination of genetic diversity [9], food analysis [10, 11], criminal investigation in forensics and immigration [12], and environmental monitoring [8]. Different techniques have been proposed for the detection of target DNA, such as electrochemical sensing [13], fluorescence [14], chromatography in tandem with mass spectrometry [15], surface plasma resonance [16], and oligonucleotide microarray and DNA [17]. The detection of DNA is an area of excellent interest as it plays a main role in clinical, pharmaceutical, and forensic applications. Electrochemical transducer offers several advantages, such as high sensitivity, simplicity, inexpensiveness, and accurate specificity for converting DNA hybridization results into useful analytical signals [18–21].

The electrochemical DNA biosensor devices based on the principle of nanotechnology have become one of the

most exciting fields in analytical chemistry. This has been facilitated by the accessibility of various nanomaterials, for example, nanotubes [22], magnetic particles/nanoparticles [23, 24], and nanowires [25].

Gold nanoparticles are widely used in immobilization of DNA probe because of their unique characteristics, such as strong adsorption ability, high biocompatibility, and great surface area [26]. In this study, we have developed an easy to fabricate which were acted as the electrode for DNA detection by using GNPs synthesis on thermally oxidized SiO₂. Prior to the probe DNA immobilization and target DNA hybridization detection, the SiO₂ thin films surface was modified with GNPs due to its well-known chemistry, superior capacitance, and huge attachment surfaces. A novel, label-free biosensor and sensitive DNA sensor.

2. Materials and Methods

2.1. Preparation of GNPs Solution. Gold nanoparticles (GNPs) were used in this project for the immobilization and hybridization of the DNA on the SiO₂ thin films. Firstly, a HAuCl₄ solution with the concentration of 0.49 mol/L was prepared by dissolving 500 mg of HAuCl₄ into 3 mL of 10% HCl. Then, a diluted 0.2 mM of HAuCl₄ solution was made by adding 40 μL (19.6 μmol) of HAuCl₄ solution into 100 mL of deionized water as to produce solution A. Secondly, 558.79 mg of trisodium citrate was added into 50 mL of deionized water to make a solution B. The concentration of the solution was controlled at 38.8 mmol/L. Solution A was brought to a rolling boil at 150°C with stirring vigorously as to get a homogenous size of the GNPs solution. 10 mL of 38.8 mM of sodium citrate was added rapidly into the vortex of the solution. The solution resulted in a color change from pale yellow to red. Boiling and stirring were continued for another 10 min. The heating was then removed, and stirring was continued for an additional 15 min. When the solution cooled down to room temperature, it was filtered through a 0.8 μm membrane filter paper. The prepared solution was kept in the refrigerator with the temperature 4°C and measured by using UV-Vis with the wavelength 400 nm to 800 nm.

2.2. Modification of SiO₂ with GNPs. A p-type silicon (100) wafer (1 cm × 1 cm) was cleaned by using acetone and isopropanol in ultrasonic for about 15 minutes and was immersed into the buffered oxide etch (BOE) solution and washed with deionized water followed by oxidation process for 30 minutes. After oxidation, the silicon oxide (SiO₂) layer of thickness ~50 nm, the aluminium (99.99% of purity) was deposited on the backside of the Si using thermal evaporator. The selectivity of the DNA biosensor was studied using the GNPs/APTES/SiO₂/Si/Al electrode. The SiO₂ surface was functionalized with APTES solution which was prepared by mixing of 2% APTES with 93% of ethanol and 5% of deionized water. The silanyl group (-SH₃) presented in APTES was used for the process of silanization, which was chemically attached with the hydroxyl-rich SiO₂ [27]. Besides that, amino group (NH₂-) presented in APTES was served as a glue layer to attach the GNPs which linked to probe DNA.

Attachment between APTES and GNPs is shown in Figure 1. For the surface modification of SiO₂ with APTES, 10 μL of prepared APTES solution on the SiO₂ surface and incubated for 2 hours. Then, the surface washed for 3 times in blow dried the surface and drop 10 μL of GNPs on the surface at 150°C for 20 min on hotplate. This step was repeated 3 times to obtain enough GNPs on the SiO₂ surface and electrode is ready for electrical characterization.

2.3. Probe DNA Immobilization on Modified GNPs. Probe DNA was purchased from 1st BASE Pte Ltd. (Malaysia). The probe DNA sequences were 5'-CTG ATA GTA GAT TTG TGA CCG TAGAAA-C6. Probe DNA was dropped onto the GNPs modified SiO₂ electrode for immobilization and incubated at room temperature for 0.5, 1, 2, and 4 hours. After a period of time, the electrode was carefully washed by using deionized water to remove any unbonded DNA probe and dried at room temperature. The probe-modified devices were denoted as DNA/GNPs/APTES/SiO₂/Si/Al and then were ready for electrochemical measurements.

2.4. Hybridization of DNA. Hybridization of DNA used in this project was purchased from 1st BASE Pte Ltd. (Malaysia). Hybridization with complementary DNA sequences was 5'-CTA CGG TCA TCA CAA ATC TAC TAT CAG-3'. To hybridize the DNA, 10 μL of 10 μM complementary DNA was dropped onto GNPs electrode and incubated for 2 hours. After that, the GNPs electrode was washed by using deionized water to remove any nonhybridized DNA and dried at room temperature. 10 μL of 0.5 μM methylene blue was then dropped onto the GNPs electrode and incubated again for 3 minutes. Finally, the GNPs electrode will once again be washed with deionized water to remove any excess of methylene blue and the GNPs electrode is ready to be electrically measured once it has dried.

2.5. Electrochemical Measurements. Electrochemical measurement was performed by using dielectric analyser. The tests were conducted by using Ag/AgCl as the reference electrode and GNPs-modified electrode as a working electrode. The Al acts as a back gate. The responses of the DNA immobilization were investigated in 10 μM potassium hexacyanoferrate III, K₃Fe(CN)₆ aqueous solution containing 0.1 M KCl as electrolyte. A schematic view of testing measurement for DNA detection is shown in Figure 2.

3. Results and Discussion

3.1. Measurement of UV-Vis Spectroscopy. The characterization of prepared GNPs solution was examined using an UV-Vis spectroscopy. The measurements were carried out within the wavelength range of 400–800 nm under ambient conditions and the result is shown in Figure 3. The absorbance maximum was found at 530 nm, which was indicative of GNPs of diameter 35 ± 5 nm [28]. The particle size was further confirmed using the method described by Haiss et al. [29].

3.2. Capacitance Measurement. The dielectric behaviour of GNPs modified surface for DNA detection was investigated using dielectric analyzer. Figure 4 demonstrates the

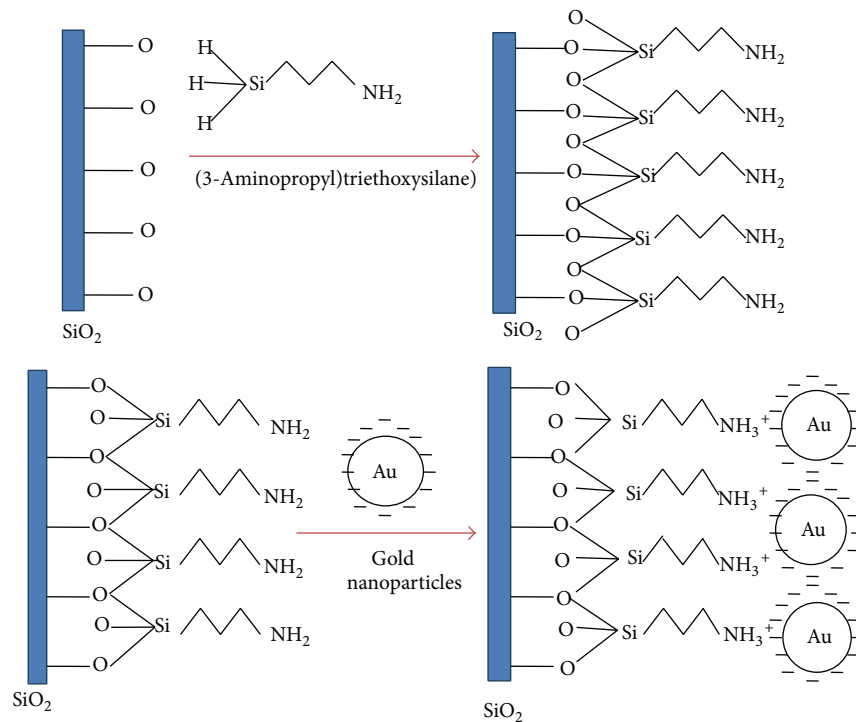

FIGURE 1: Surface modification of SiO₂ with GNPs using APTES.

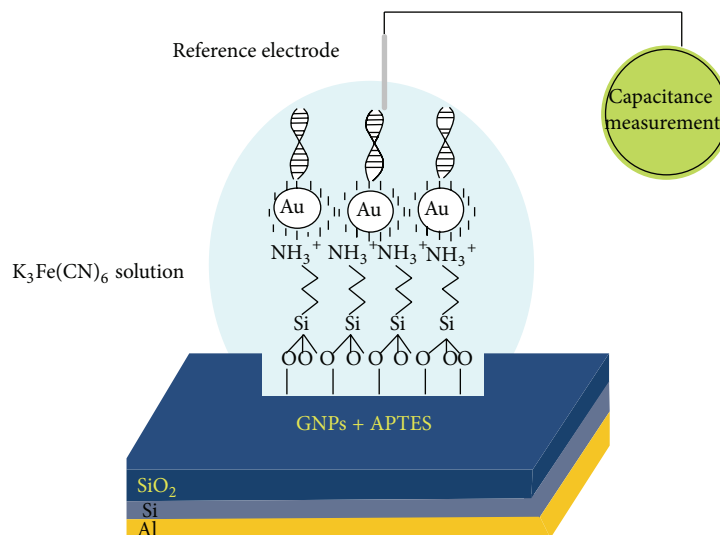

FIGURE 2: A schematic illustration of testing measurement of a modified GNPs electrode and the hybridization of DNA using APTES.

capacitance-frequency (C-F) characterization by connecting two-point probe. The change in capacitance before and after immobilization of the DNA onto the GNPs-modified electrode was carried out in the frequency range of 1 Hz to 1 MHz on the same sample. The result shows that the capacitance values were 160 μF , 77.8 μF , 70 μF , and 64.6 μF , respectively, at 1 Hz for DNA immobilization on the devices during periods of time in 30 min to 4 hours. The capacitance value for bare device was 0.42 μF that was set as a base line. The result indicated that the electrode device exhibited the lowest capacitance value of 64.6 μF at period of 4 hours and

the highest capacitance value of 160 μF in 30 minutes after DNA immobilized onto modified GNPs. The difference value of capacitance in DNA immobilization and hybridization in 30 min has shown the largest capacitance value whereby confirming that 30 min is the best period for DNA immobilization and hybridization. Furthermore, the capacitance values for GNPs modified surface are higher than the bare device. This is probably because the APTES is a conducting polymer material that performs a better capacitance signal compared with the bare device. The immobilization of DNA was successfully detected by showing the highest capacitance

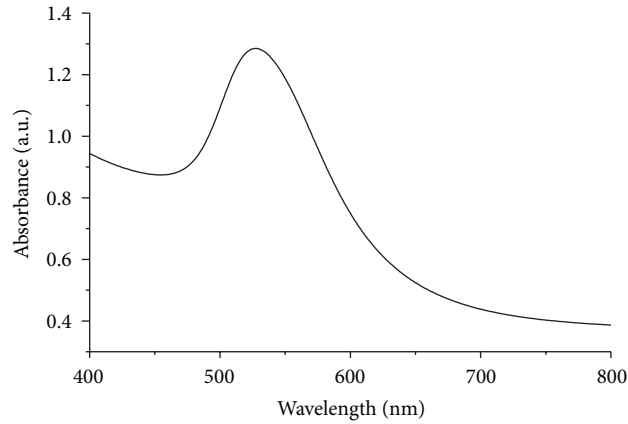
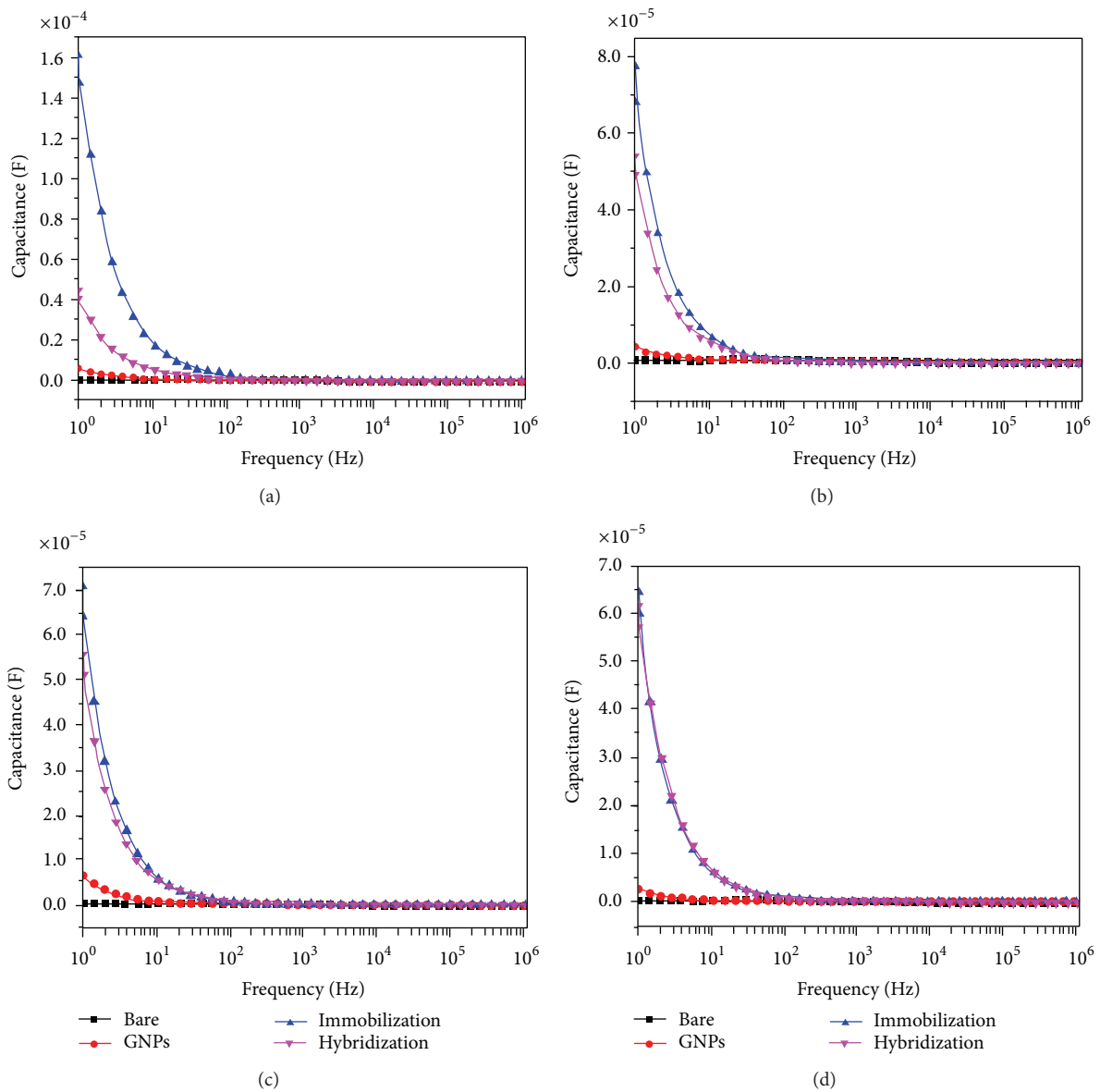

FIGURE 3: UV-visible spectra of Au-nanoparticles solution.

FIGURE 4: A capacitance as a function of frequency for GNPs-modified SiO₂ thin films for DNA immobilization and hybridization detection after (a) 30 minutes, (b) 1 hour, (c) 2 hours, and (d) 4 hours.

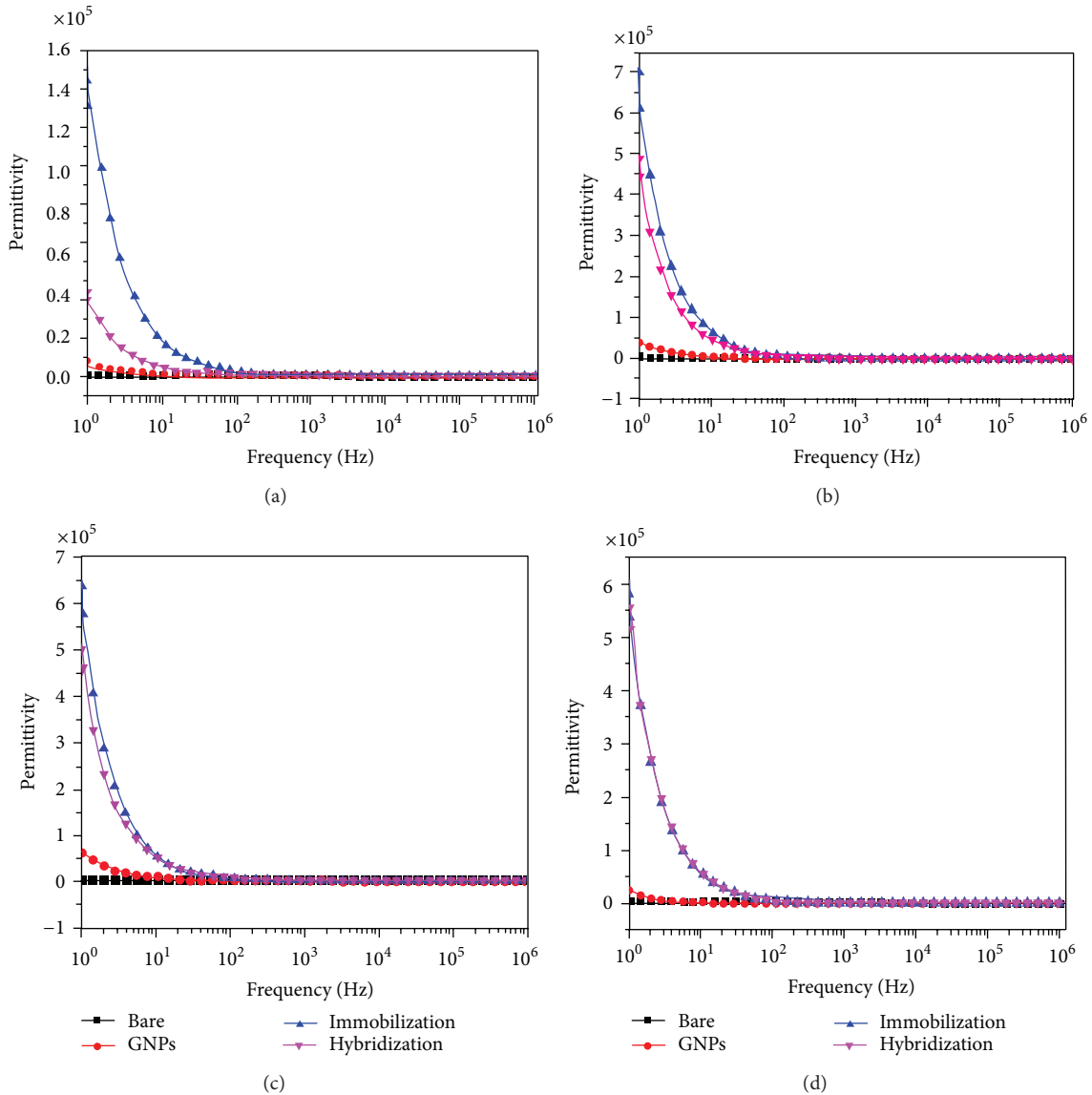

FIGURE 5: A permittivity as a function of frequency for GNPs-modified SiO_2 thin films for DNA immobilization and hybridization detection after (a) 30 minutes, (b) 1 hour, (c) 2 hours, and (d) 4 hours.

values onto the modified GNPs electrode in 30 min. On the other hand, during hybridization of the DNA, the methylene blue was bound in base pairs of double strand DNA selectively that reflected the capacitance values of the sample measured were $44 \mu\text{F}$, $54 \mu\text{F}$, $55 \mu\text{F}$, and $61.5 \mu\text{F}$, respectively, in 30 min to 4 hours. Therefore, this result confirming the behavior of DNA immobilization and hybridization reaction was successfully detected using a GNPs-modified electrode.

3.3. Permittivity Measurement. The permittivity measurements were also performed on the same device as shown in Figure 5. These measurements have the same direction with the capacitance measurement whereby it gives the largest changes in permittivity with probe DNA immobilization. It is clearly observed that permittivity increased dramatically which resulted in the permittivity values being 1450×10^3 , 700×10^3 , 630.6×10^3 , and 580×10^3 for DNA immobilization

during period of time of 30 min to 4 hours. The capacitance measurements started to significantly increase from a frequency of ~ 1 Hz and degraded as the frequency increases. The result revealed that permittivity measurement gives more sensitivity at lower frequency during hybridization. The permittivity values during hybridization were 399×10^3 , 480×10^3 , 500×10^3 , and 554×10^3 , respectively. This work demonstrated that changes in capacitance and permittivity value of the GNPs-modified electrode during probe DNA immobilization and hybridization ensure the presence of the DNA during the measurement using GNPs electrode.

4. Conclusions

In conclusion, we have demonstrated the DNA immobilization and hybridization on GNPs-modified SiO_2 thin film as electrode device. The difference of the capacitance and

permittivity value during immobilization and hybridization had successfully conducted in electrolyte solution. The capacitance and permittivity value differences in 30 min have shown the best result for DNA immobilization and hybridization. This established GNPs based biosensing platform is potentially applied as the diagnostic or enzyme sensor application.

Conflict of Interests

The authors declare that there is no conflict of interests regarding the publication of this paper.

Acknowledgments

The work was supported by INEE at UniMAP, through the Nano Technology project; therefore, the authors thanked and wished to acknowledge the Institute of Nano Electronic Engineering (INEE) at University Malaysia Perlis (UniMAP) for supporting this work.

References

- [1] D. Imre, "Titanium dioxide and gold nanoparticle for environmental and biological application," *Annals of Faculty Engineering Hunedoara*, vol. 1, pp. 161–166, 2011.
- [2] S. R. Boddu, V. R. Gutti, T. K. Ghosh, R. V. Tompson, and S. K. Loyalka, "Gold, silver, and palladium nanoparticle/nano-agglomerate generation, collection, and characterization," *Journal of Nanoparticle Research*, vol. 13, no. 12, pp. 6591–6601, 2011.
- [3] S. A. C. Carabineiro, "Gold highlights at the 11th "Trends in Nanotechnology" International Conference (TNT 2010) in Braga, Portugal, September 6–10, 2010," *Gold Bulletin*, vol. 44, no. 1, pp. 57–62, 2011.
- [4] V. Kattumuri, *Gold nanoparticles for biomedical applications: synthesis, characterization, in vitro and in vivo studies [Ph.D. thesis]*, University of Missouri-Columbia, Columbia, Mo, USA, 2006.
- [5] D. B. Sanchez, *The Surface plasmon resonance of supported noble metal nanoparticles: characterization, Laser Tailoring, and SERS Application [Ph.D. thesis]*, Madrid University, Madrid, Spain, 2007.
- [6] L. C. Courrol, F. R. de Oliveira Silva, and L. Gomes, "A simple method to synthesize silver nanoparticles by photo-reduction," *Colloids and Surfaces A: Physicochemical and Engineering Aspects*, vol. 305, no. 1–3, pp. 54–57, 2007.
- [7] S.-F. Liu, Y.-F. Li, J.-R. Li, and L. Jiang, "Enhancement of DNA immobilization and hybridization on gold electrode modified by nanogold aggregates," *Biosensors and Bioelectronics*, vol. 21, no. 5, pp. 789–795, 2005.
- [8] M. E. Ali, M. Kashif, K. Uddin, U. Hashim, S. Mustafa, and Y. Che Man, "Species authentication methods in foods and feeds: the present, past, and future of halal forensics," *Food Analytical Methods*, vol. 5, no. 5, pp. 935–955, 2012.
- [9] L. Hood and D. Galas, "The digital code of DNA," *Nature*, vol. 421, no. 6921, pp. 444–448, 2003.
- [10] M. E. Ali, S. Mustafa, U. Hashim, Y. B. Che Man, and K. L. Foo, "Nanobioprobe for the determination of pork adulteration in burger formulations," *Journal of Nanomaterials*, vol. 2012, Article ID 832387, 7 pages, 2012.
- [11] M. E. Ali, S. Mustafa, Y. B. Che Man, K. N. Adam, and K. N. Humayun, "Nanobiosensor for the detection and quantification of pork adulteration in meatball formulation," *Journal of Experimental Nanoscience*, vol. 9, no. 2, pp. 152–160, 2014.
- [12] M. J. Heller, "DNA microarray technology: devices, systems, and applications," *Annual Review of Biomedical Engineering*, vol. 4, pp. 129–153, 2002.
- [13] W. Zhang, T. Yang, D. M. Huang, and K. Jiao, "Electrochemical sensing of DNA immobilization and hybridization based on carbon nanotubes/nano zinc oxide/chitosan composite film," *Chinese Chemical Letters*, vol. 19, no. 5, pp. 589–591, 2008.
- [14] D. W. Selinger, K. J. Cheung, R. Mei et al., "RNA expression analysis using a 30 base pair resolution *Escherichia coli* genome array," *Nature Biotechnology*, vol. 18, no. 12, pp. 1262–1268, 2000.
- [15] P. B. Farmer, K. Brown, E. Tompkins et al., "DNA adducts: mass spectrometry methods and future prospects," *Toxicology and Applied Pharmacology*, vol. 207, no. 2, pp. s293–s301, 2005.
- [16] K. M. Byun, N.-H. Kim, Y. H. Ko, and J. S. Yu, "Enhanced surface plasmon resonance detection of DNA hybridization based on ZnO nanorod arrays," *Sensors and Actuators B: Chemical*, vol. 155, no. 1, pp. 375–379, 2011.
- [17] H. Guan, M. Cai, L. Chen, Y. Wang, and Z. He, "Label-free DNA sensor based on fluorescent cationic polythiophene for the sensitive detection of hepatitis B virus oligonucleotides," *Luminescence*, vol. 25, no. 4, pp. 311–316, 2010.
- [18] D.-J. Chung, K.-C. Kim, and S.-H. Choi, "Electrochemical DNA biosensor based on avidin-biotin conjugation for influenza virus (type A) detection," *Applied Surface Science*, vol. 257, no. 22, pp. 9390–9396, 2011.
- [19] R. Lao, S. Song, H. Wu et al., "Electrochemical interrogation of DNA monolayers on gold surfaces," *Analytical Chemistry*, vol. 77, no. 19, pp. 6475–6480, 2005.
- [20] S. Siddiquee, N. A. Yusof, A. B. Salleh, S. G. Tan, and F. A. Bakar, "Electrochemical DNA biosensor for the detection of *Trichoderma harzianum* based on a gold electrode modified with a composite membrane made from an ionic liquid, ZnO nanoparticles and chitosan, and by using acridine orange as a redox indicator," *Microchimica Acta*, vol. 172, no. 3–4, pp. 357–363, 2011.
- [21] D. Jiang, G. Xiang, C. Liu, J. Yu, L. Liu, and X. Pu, "Development of a cyclic voltammetry method for DNA electrochemical detection on microfluidic gene chip," *International Journal of Electrochemical Science*, vol. 7, pp. 10607–10619, 2012.
- [22] A. Erdem, M. I. Pividori, A. Lermo, A. Bonanni, M. D. Valle, and S. Alegret, "Genomagnetic assay based on label-free electrochemical detection using magneto-composite electrodes," *Sensors and Actuators B: Chemical*, vol. 114, no. 2, pp. 591–598, 2006.
- [23] A. Erdem, F. Sayar, H. Karadeniz, G. Guven, M. Ozsoz, and E. Piskin, "Development of streptavidin carrying magnetic nanoparticles and their applications in electrochemical nucleic acid sensor systems," *Electroanalysis*, vol. 19, no. 7–8, pp. 798–804, 2007.
- [24] H. Karadeniz, A. Erdem, A. Caliskan, C. M. Pereira, E. M. Pereira, and J. A. Ribeiro, "Electrochemical sensing of silver tags labelled DNA immobilized onto disposable graphite electrodes," *Electrochemistry Communications*, vol. 9, no. 9, pp. 2167–2173, 2007.
- [25] M. A. Lapiere-Devlin, C. L. Asher, B. J. Taft, R. Gasparac, M. A. Roberts, and S. O. Kelley, "Amplified electrocatalysis at DNA-modified nanowires," *Nano Letters*, vol. 5, no. 6, pp. 1051–1055, 2005.

- [26] J. Wang, "Nanoparticle-based electrochemical DNA detection," *Analytica Chimica Acta*, vol. 500, no. 1-2, pp. 247–257, 2003.
- [27] X. Hou, L. Wang, G. He, and J. Hao, "Synthesis optical and electrochemical properties of ZnO nanorod hybrids loaded with high-density gold nanoparticles," *CrystEngComm*, vol. 14, no. 16, pp. 5158–5162, 2012.
- [28] M. E. Ali, U. Hashim, S. Mustafa et al., "Nanoparticle sensor for label free detection of swine DNA in mixed biological samples," *Nanotechnology*, vol. 22, no. 19, Article ID 195503, 2011.
- [29] W. Haiss, N. T. K. Thanh, J. Aveyard, and D. G. Fernig, "Determination of size and concentration of gold nanoparticles from UV-Vis spectra," *Analytical Chemistry*, vol. 79, no. 11, pp. 4215–4221, 2007.

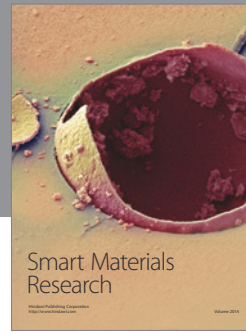
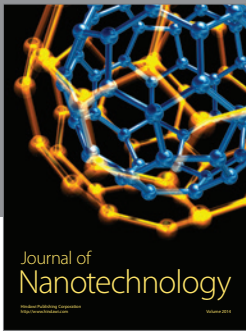

Hindawi

Submit your manuscripts at
<http://www.hindawi.com>

